

<THESE INSTRUCTIONS MUST BE GIVEN TO THE END USER>



B&W Trailer Hitches
 1216 Hawaii Rd / PO Box 186
 Humboldt, KS 66748
 P:620.473.3664
 F:620.473.3766

Call or Email us for
 Installation Support
 hitches@turnoverball.com
 www.turnoverball.com

Cab Protector Installation Instructions

PUCP7500

PUCP7500WA, PUCP7500BA

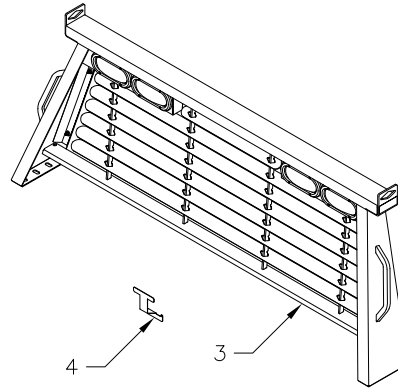
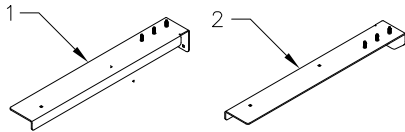

Required tools: Installation of the Cab Protector requires a torque wrench capable of measuring 20 ft-lbs, a 1/2" socket, a 9/16" socket and a 5/16" Drill bit and drill.

HITCH ASSEMBLY PARTS LIST		
ITEM	DESCRIPTION	QTY
1	Left Bed Protector	1
2	Right Bed Protector	1
3	Cab Protector	1
4	Drill Location Bracket	1

HARDWARE KIT		
DESCRIPTION	QTY	
5/16" X 1 1/2" Carriage Bolts	4	
5/16" X 3/4" Carriage Bolts	2	
5/16" Flat Washers	6	
5/16" Lock Washers	6	
5/16" Hex Finish Nuts	6	
3/8" Large Flat Washers	6	
3/8" Lock Washers	6	
3/8" Hex Finish Nuts	6	



Failure to comply with the safety information in these instructions could result in serious injury or death.

⚠ Read all installation and operating instructions along with all labels before using this product.

⚠ Do not modify this product in any manner. Doing so could alter its integrity and lead to a loss of attachment between the Cab Protector and truck.

⚠ This installation must be completed by someone who is aware of the hazards involved. This person must be knowledgeable of proper safety procedures for a vehicle modification of this nature, and for usage of the equipment required to perform the installation.

INSTALL BED PROTECTORS

- Verify proper fit of Cab Protector.** Place the bed protectors on the pickup sides as shown in figure A1. Make sure the long flanges are pulled tight against the front of the bed, see figure A2, and the short flange should be pushed against the inside of the bed sides. Measure across the truck from the center of the middle threaded stud on the driver side to the center of the middle stud on the passenger side. Next measure the distance between the centers of the slots at the bottom of the cab protector. The two measurements should be within 1/2" of each other.
- Drill hole locations.** With the bed protectors in the same location as step one, check under the bed rail in the location of each hole to be drilled. Make sure there are no lights, wires, or other obstructions and that the drill location is solid and does not have holes or plastic features. Mark the center of the two holes in the top of each bed protector. Drill a 5/16" hole into the top of the bed rail at each center mark.
- Adhesive pads (optional).** If the sides of the bed are not protected, adhesive pads are available for installation on the bed protectors. To install, place the pads as far as possible from on another without covering any holes or hardware.

- Install bed protectors.** Insert a 5/16" X 1-1/2" Carriage bolt in each of the drilled holes and secure using a flat washer, lock washer and finish nut. Fasten the bed protectors into place but do not fully tighten hardware at this time.

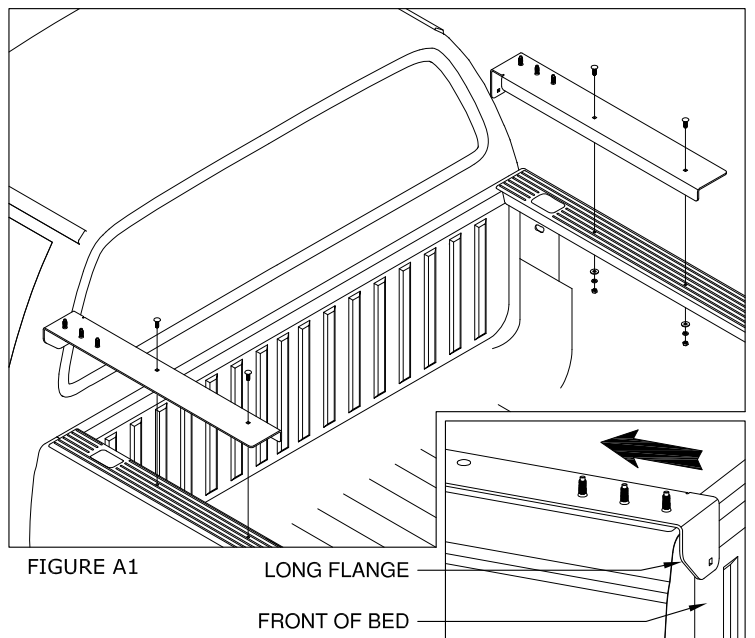
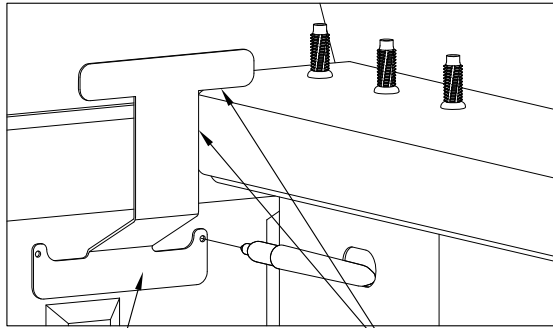

FIGURE A2: PASSENGER BED CORNER

5. **Mark forward hole location.** Using the provided Drill Location Bracket mark the location of the forward bolt location. Start by aligning the the bracket so it is flat against the front surface of the bed, then, aligning the top "T" portion of the bracket with the top and side of the Bed protector, as shown in figure A3.



FLAT AGAINST FRONT OF BED

FIGURE A3: PASSENGER SIDE OF BED

FLUSH WITH TOP AND FLANGE OF BED PROTECTOR

6. **Drill 5/16" forward hole.** Once you have marked the hole location use a center punch to prepare for drilling. Drill the hole using a 5/16" drill. The drill may drift a little as it finds the center of the matching hole in the bed protector, see figure A4.

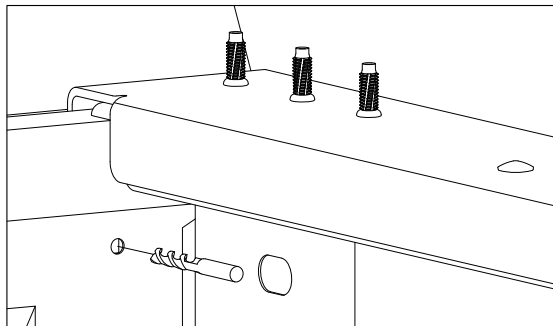

FIGURE A4: PASSENGER SIDE OF BED

7. **Install forward bolt connection.** From the gap between the bed and the cab insert a 5/16" X 3/4" Carriage bolt into the Bed Protector and secure using a flat washer, lock washer and finish nut, as shown in figure A5 Do not fully tighten hardware at this time.

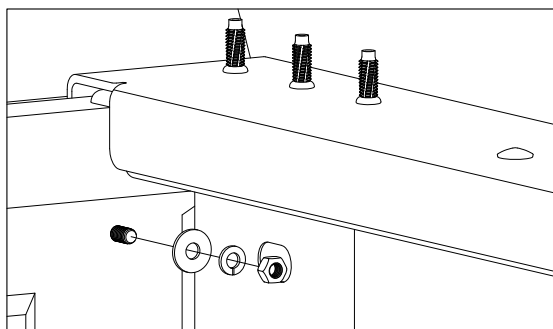

FIGURE A5: PASSENGER SIDE OF BED

8. **REPEAT STEPS 5 - 6 FOR DRIVER SIDE.**

INSTALL CAB PROTECTOR

⚠ WARNING: Components of the Cab Protector are heavy and cumbersome to handle. Failure to use proper lifting techniques and an adequate amount of people when moving and handling the Cab Protector could result in property damage or serious injury.

1. **Install Cab Protector.** Position the slots on the bottom of the cab protector over threaded studs on the bed protectors, See figure B1. Fasten the cab protector with the provided 3/8" Large flat washers, lock washers, and finish nuts. Do not fully tighten. Make sure the cab protector is centered with the truck as viewed from the rear.

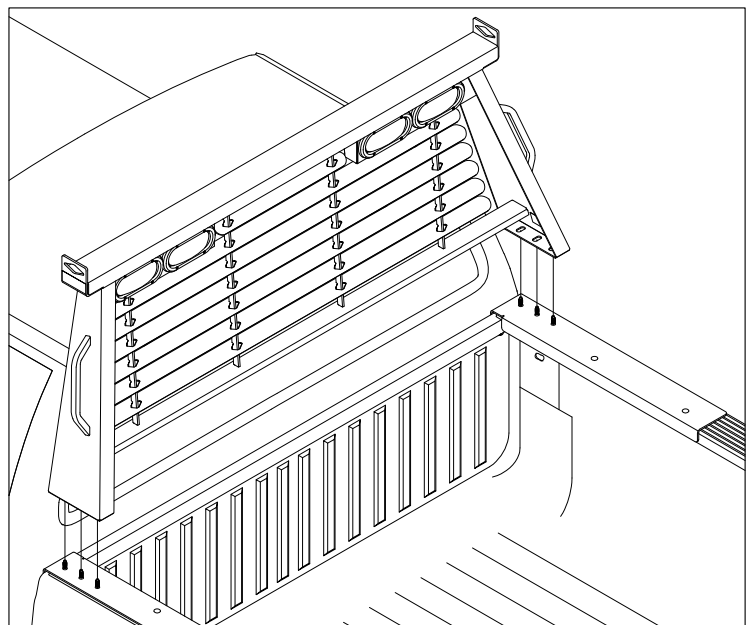

FIGURE B1

2. **Tighten hardware.** First secure the bed protectors to the truck. Torque the six finish nuts to 18 foot-pounds. next torque the 6 nuts on the cab protector to no more than 20 foot-pounds.
3. **Install Wiring.** Splice the tail of the cab protector wiring harness into the vehicle's wiring. The Green wire is for the passenger side turning signal and braking. The Yellow wire is for the driver side turning signal and braking. The brown wire is for clearance. The white wire is for ground. Remove excess wire so that there is not any loose wiring. Be sure that wiring is protected from sharp edges or other obstacles that could damage the wires. When installed correctly the two outside lights will function as stop, turn, and tail while the inside two lights will only function as tail lights.