



# **MPD-67-PSD-11-22ICPIPEFIX**

## **INSTALL INSTRUCTIONS**



# 1. !!! Disconnect batteries !!!

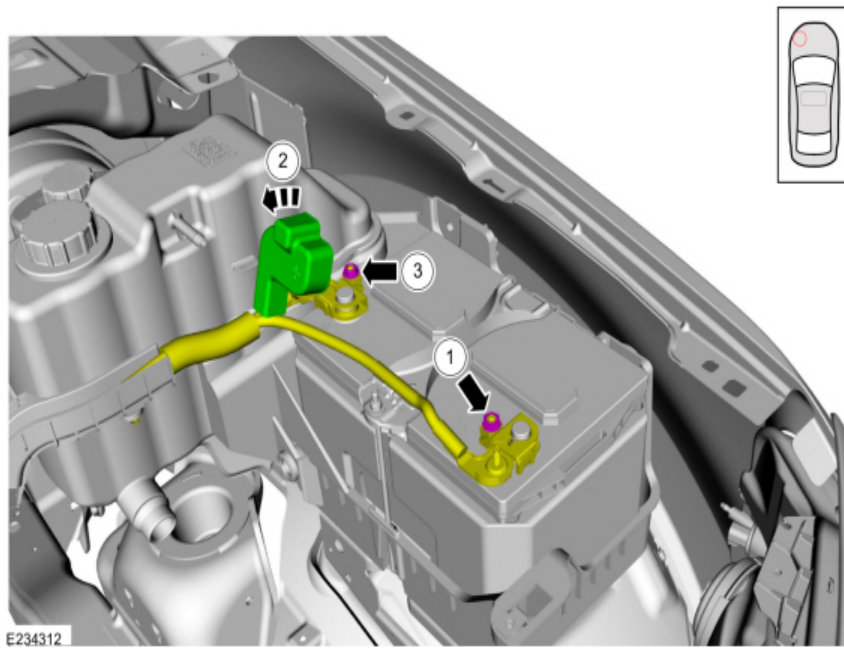
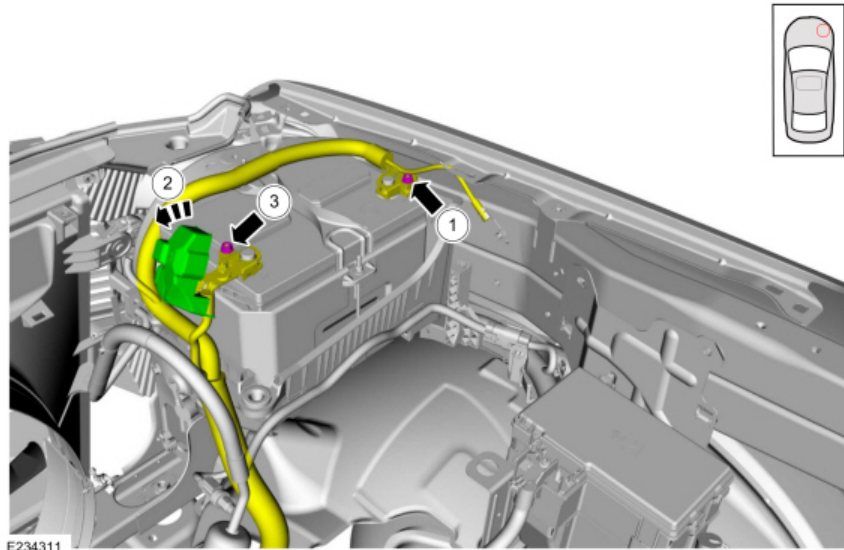

2. Disconnect the CAC temperature sensor electrical connector.
3. Detach the retainer and position the wiring harness aside.

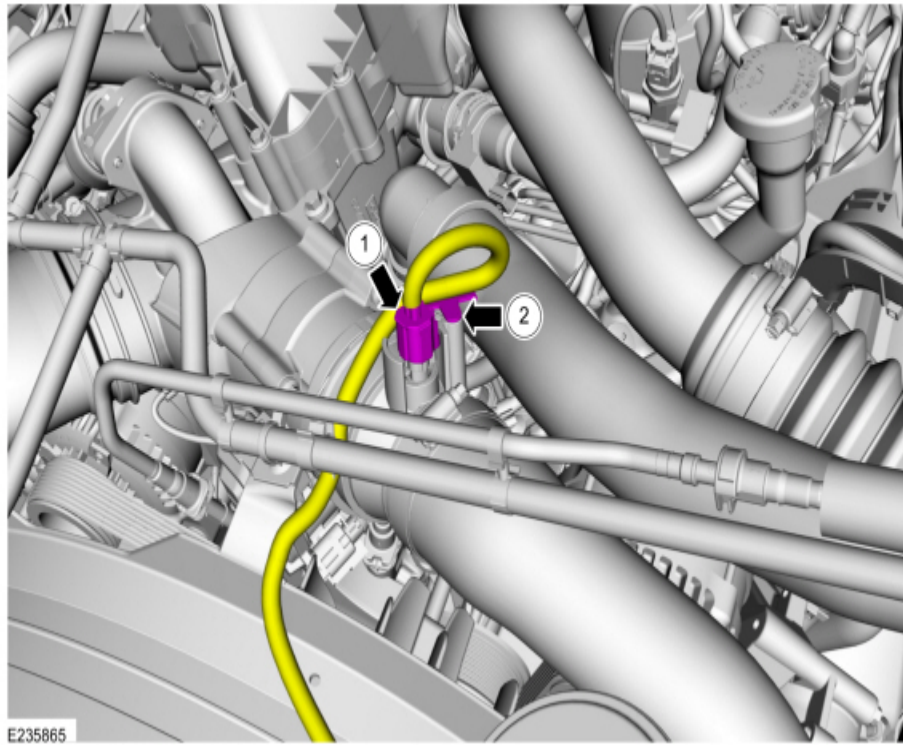

4. Loosen the clamp.  
*Torque: 48 lb.in*

5. Release the clip and remove the CAC outlet pipe.

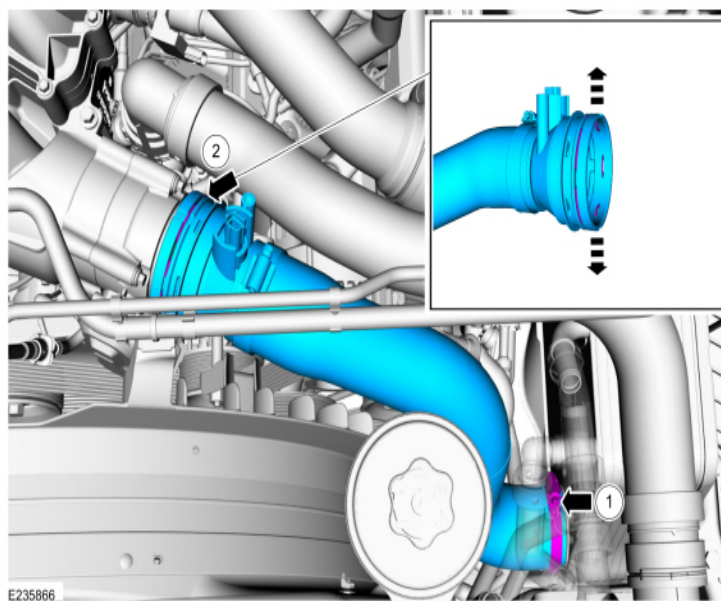

6. Disconnect the TB (throttle body) electrical connector, and ziptie away as this is no longer used with this kit.

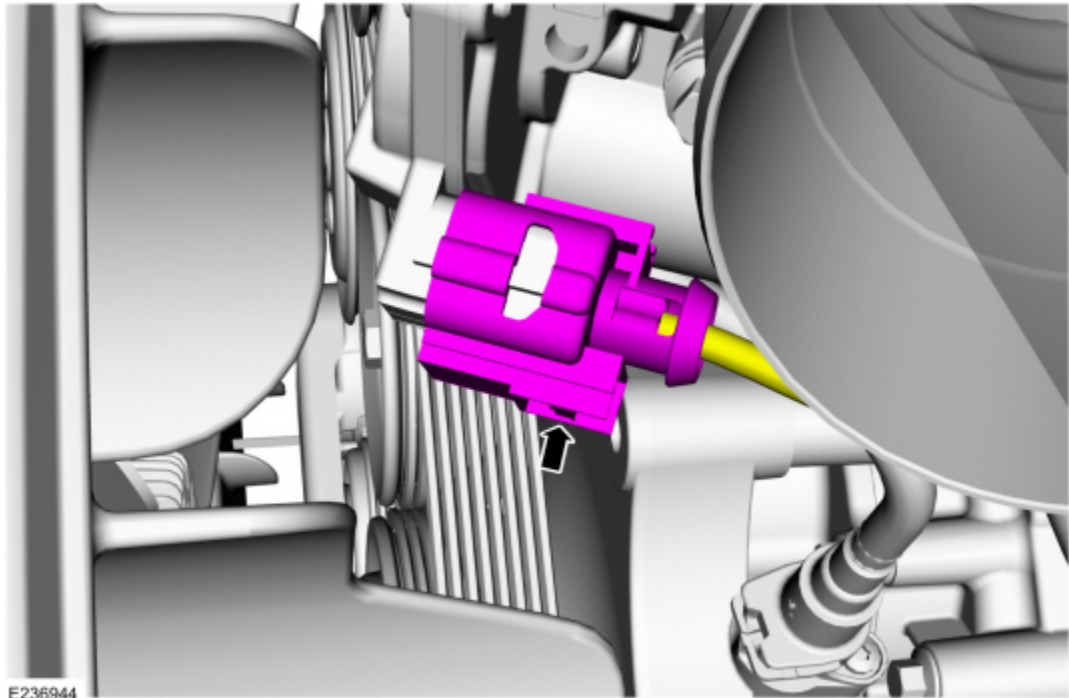

7. Remove the TB (throttle body) retaining bolts and then remove the TB (throttle body).

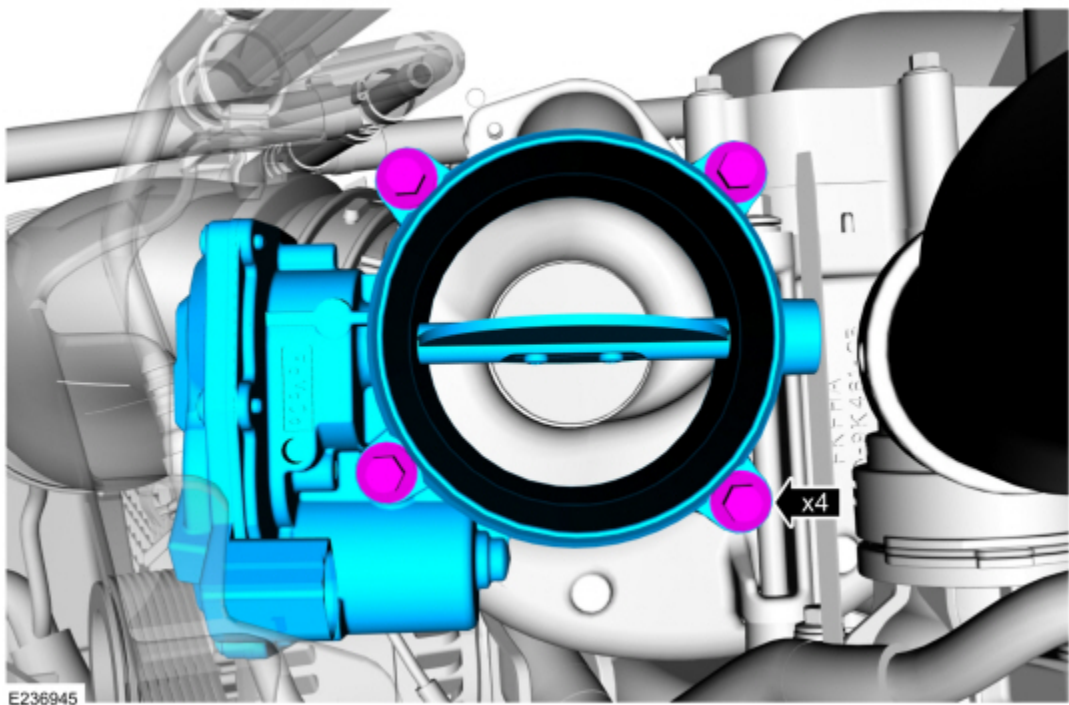

8. Remove and discard the TB (throttle body) gasket new part has a o'ring seal.

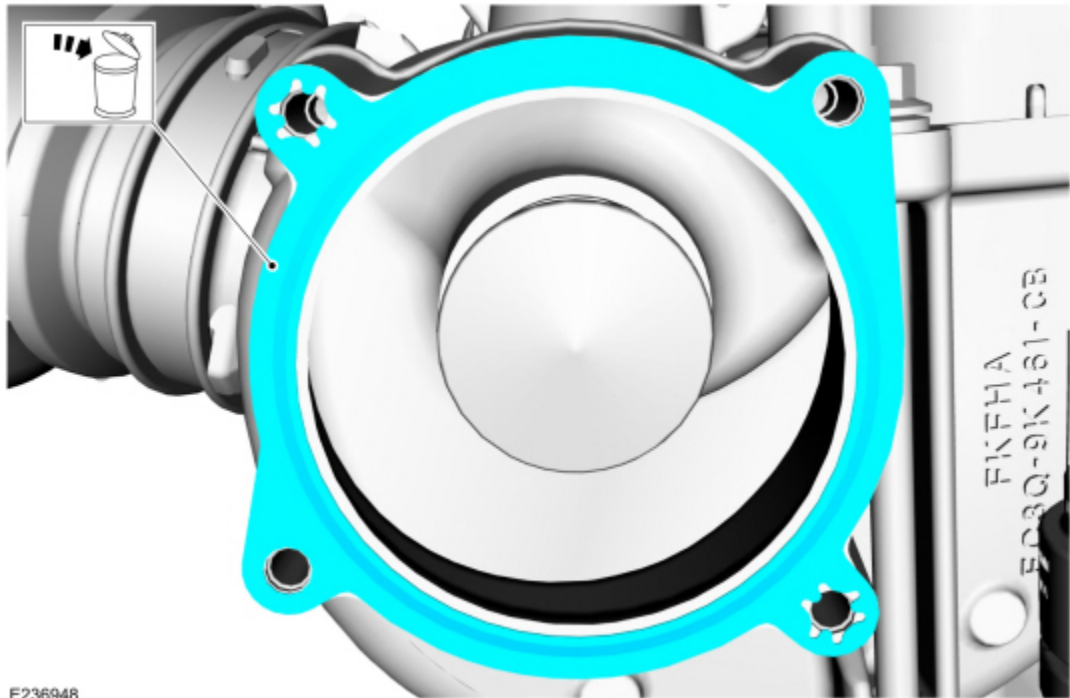

**NOTICE: Make sure that the mating faces are clean and free of foreign material.**

9. Install the newly provided billet throttle valve adapter supplied in kit, then install and tighten the billet throttle valve adapter retaining bolts in a even pattern to

**Torque: 96 lb.in**

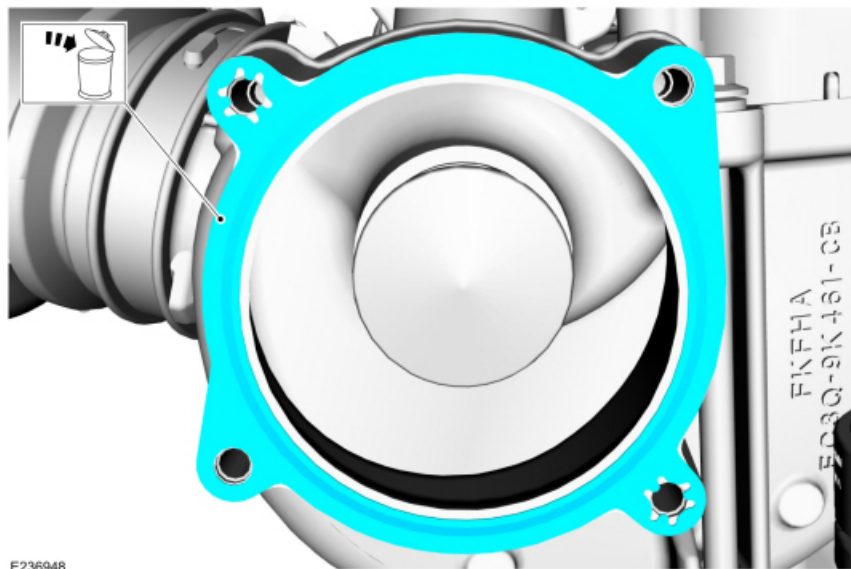

**10. Install the provided mandrel bent pipe in place of the factory one you just removed using the supplied silicone boots and 4 hd clamps and tighten**

**!!!We suggest using some soapy water or window cleaner to lubricate boots to aid in easier installation and clocking of the boots for the new pipe to be installed. Please do not use oil or grease to slide boots on or you will have problems with hoses blowing off under boost!!!**

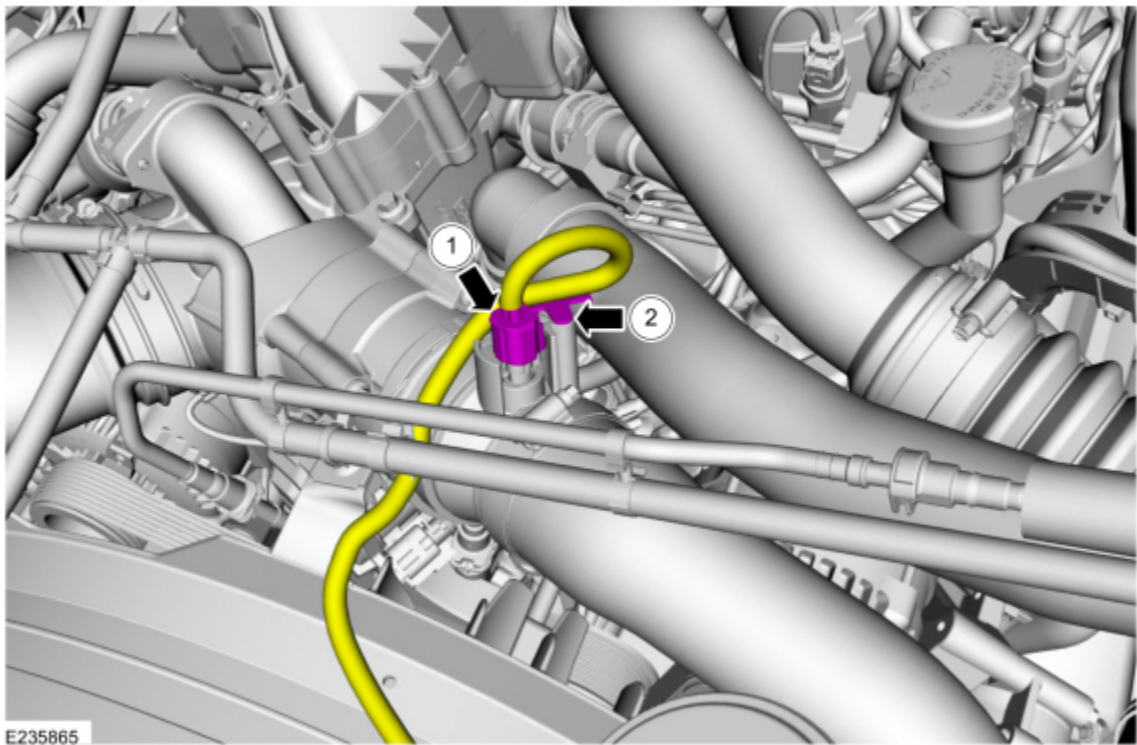

**11. Reinstall Intake Air Temperature sensor pictured above into the new bung that is on the new pipe and reconnect harness and route wire so they do not get caught by the fan or other objects.**

## 12. Re-Connect the batteries.

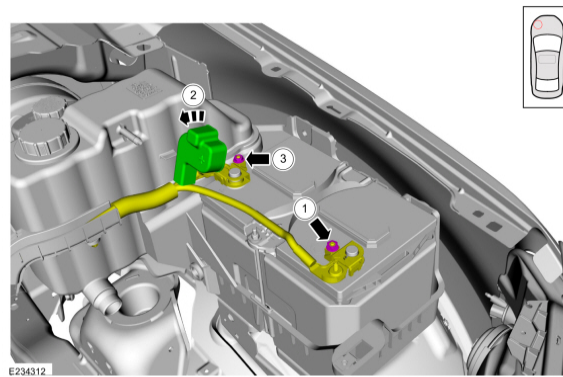
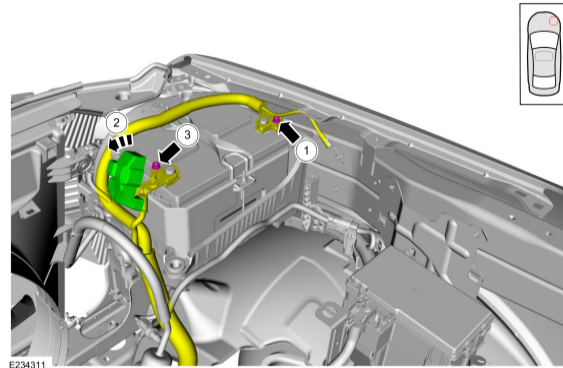

**THANK YOU FOR YOUR CONTINUED SUPPORT AND PURCHASES FROM**  
**Maryland Performance Diesel**  
**5199 Raynor Ave**  
**Linthicum Heights, MD 21090**  
**WWW.SHOPMPD.COM**